

# WAFER CHECK VALVE 300 PSI

MODEL LVWCV



EX26984



## FEATURES:

- The extremely short face to face dimension and compact design of this valve allow installation and service in tight spaces
- Spring assisted for better dynamic behavior
- Soft seated for perfect tightness even at low differential pressure
- Can be installed vertically or horizontally
- The 4" size is provided with 1/2" pipe plug in drain port as standard configuration
- Flanges to ANSI B16.1 CLASS125
- Working pressure 300 PSI
- Working temperature -10°C to 82°C
- Spray-painted or fusion bonded epoxy coated interior and exterior to AWWA C550 standard for corrosion protection

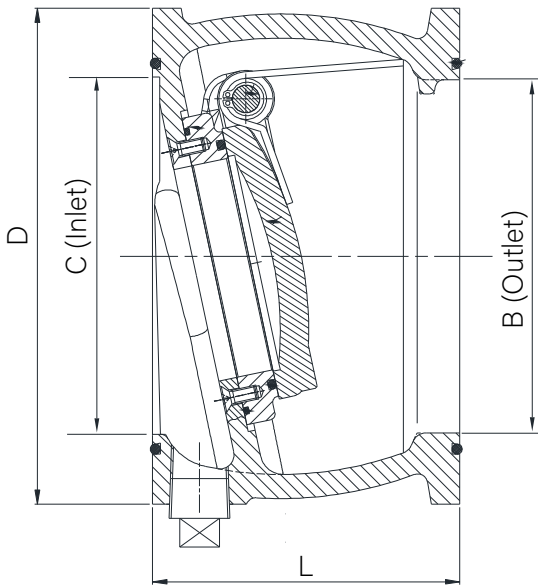

MATERIAL SPECIFICATIONS		
PART	MATERIAL	ASTM SPECIFICATION
Body	Ductile Iron	A536 Class 65-45-12
Body Seat Ring	Bronze	B62 C83600
Seat O-Ring	Rubber	D2000 NBR
Disc	Bronze	B62 C83600
Spring	Stainless Steel	A276 Grade 302
Set Screw	Stainless Steel	A276 Grade 304
Hinge Pin	Stainless Steel	A276 Grade 304
Pin Retainer	Carbon Steel	A105

DIMENSIONS (In.)			
SIZE	4	6	8
L	4.25	3.75	3.75
D	6.75	8.50	11.0
B (OUTLET)	4.88	6.660	8.60
C (INLET)	4.96	6.14	7.70

PROJECT	APPROVAL STAMP
PROJECT:	<input type="checkbox"/> APPROVED
ADDRESS:	<input type="checkbox"/> APPROVED AS NOTED
ENGINEER:	<input type="checkbox"/> NOT APPROVED
SUBMITTAL DATA:	REMARKS:
NOTES 1:	
NOTES 2:	