

SINGLE CLAPPER SIAMESE THREADED & GROOVED OUTLET

MODEL LV-FDC-S - STRAIGHT



LV-FDC-S- GROOVED OUTLET



MODEL LV-FDC-S
THREADED OUTLET

DESCRIPTION:

- **Size:** 4" NPT Outlet or Grooved, (2) 2½" Inlets
- **Type:** Straight Pattern
- **Finishes:** Rough Brass Polished Chrome
- Allows up to 500 GPM to supplement the system water supply for fire protection

The Grooved or Threaded Pattern Fire Department Connection is UL Listed and FM Approved. It is manufactured from brass* components to increase its service life. The single clapper design features a brass clapper and brass seats within a cast brass body. The 2½" inlets are pin lug design for ease of use and compatibility with local fire service districts. Swivel gaskets are included. Breakable caps or plugs should be installed to protect the threads and prevent debris from being accidentally introduced into the water way.

INSTALLATION:

Installation of the Fire Department Connection is achieved with readily available job site tools. Prior to installation make sure the proper identification sign has been installed on the nipple. Coat male threads of 4" nipple liberally with a suitable pipe thread sealant such as Power Seal. Tighten FDC one full turn past hand tight. When installing the grooved FDC use a UL/FM Approved rigid coupling such as Gemlock's Style 5, 5A, 99 or 99-2 and follow the manufacturer's installation instructions. Make sure FDC is aligned according to requirements.

***DO NOT OVER TIGHTEN. OVER TIGHTENING MAY CAUSE SEVERE STRETCHING AND POSSIBLE CRACKING OF THE OF THE FDC BODY.**

GROOVED FDC SHOWN

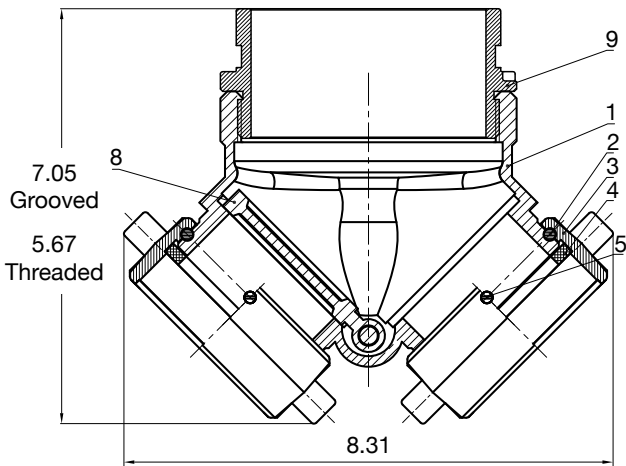

MATERIAL LIST		
NUMBER	DESCRIPTION	MATERIAL
1	Body	Brass-C37700
2	Ball Bearing	Stainless Steel-Type 304
3	Coupling (2)	Brass-C37700
4	Sealing (2)	EPDM
5	Screw (2)	Stainless Steel-Type 304
6	Hinge Pin	Brass-C37700
7	O-Ring	EPDM
8	Clapper	Brass-C37700
9*	Slot Connection	Brass-C37700

PROJECT INFORMATION	APPROVAL STAMP
PROJECT:	APPROVED
ADDRESS:	APPROVED AS NOTED
ENGINEER:	NOT APPROVED
SUBMITTAL DATA:	REMARKS:
NOTES 1:	
NOTES 2:	