

STAINLESS STEEL PIPE NIPPLES

TYPE 304 & 316

MODEL LVWPNSS



FEATURES:

- **DIMENSIONS:** ASTM A733 (See table below for standard sizes)
- **THREADS:** NPT per ASME B1.20.1
- **MATERIAL:** ASTM A-312 Sch 40 Stainless Steel Type 304 & 316
- Specials available upon request
- *Note-All Nipples in both Type 304 & 316 are available as redi cuts up to 120" long

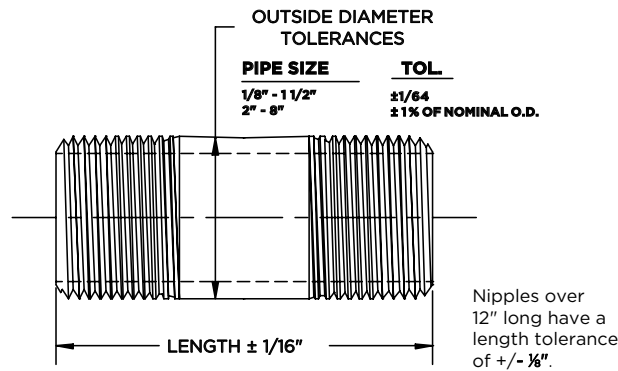

| STANDARD SIZES* | | | | | | | | | | | | | | | | | | |
|-----------------|-----------|-------|-------------|---|-------|---|-------|---|-------|---|-------|---|---|---|---|----|----|----|
| PIPE SIZE (IN) | PIPE O.D. | C L | PIPE LENGTH | | | | | | | | | | | | | | | |
| | | | 1-1/2 | 2 | 2-1/2 | 3 | 3-1/2 | 4 | 4-1/2 | 5 | 5-1/2 | 6 | 7 | 8 | 9 | 10 | 11 | 12 |
| 1/8 | 0.405 | 3/4 | 1-1/2 | 2 | 2-1/2 | 3 | 3-1/2 | 4 | 4-1/2 | 5 | 5-1/2 | 6 | 7 | 8 | 9 | 10 | 11 | 12 |
| 1/4 | 0.540 | 7/8 | 1-1/2 | 2 | 2-1/2 | 3 | 3-1/2 | 4 | 4-1/2 | 5 | 5-1/2 | 6 | 7 | 8 | 9 | 10 | 11 | 12 |
| 3/8 | 0.675 | 1 | 1-1/2 | 2 | 2-1/2 | 3 | 3-1/2 | 4 | 4-1/2 | 5 | 5-1/2 | 6 | 7 | 8 | 9 | 10 | 11 | 12 |
| 1/2 | 0.840 | 1-1/8 | 1-1/2 | 2 | 2-1/2 | 3 | 3-1/2 | 4 | 4-1/2 | 5 | 5-1/2 | 6 | 7 | 8 | 9 | 10 | 11 | 12 |
| 3/4 | 1.050 | 1-3/8 | 1-1/2 | 2 | 2-1/2 | 3 | 3-1/2 | 4 | 4-1/2 | 5 | 5-1/2 | 6 | 7 | 8 | 9 | 10 | 11 | 12 |
| 1 | 1.315 | 1-1/2 | | 2 | 2-1/2 | 3 | 3-1/2 | 4 | 4-1/2 | 5 | 5-1/2 | 6 | 7 | 8 | 9 | 10 | 11 | 12 |
| 1-1/4 | 1.660 | 1-5/8 | | 2 | 2-1/2 | 3 | 3-1/2 | 4 | 4-1/2 | 5 | 5-1/2 | 6 | 7 | 8 | 9 | 10 | 11 | 12 |
| 1-1/2 | 1.900 | 1-3/4 | | 2 | 2-1/2 | 3 | 3-1/2 | 4 | 4-1/2 | 5 | 5-1/2 | 6 | 7 | 8 | 9 | 10 | 11 | 12 |
| 2 | 2.375 | 2 | | | 2-1/2 | 3 | 3-1/2 | 4 | 4-1/2 | 5 | 5-1/2 | 6 | 7 | 8 | 9 | 10 | 11 | 12 |
| 2-1/2 | 2.875 | 2-1/2 | | | | 3 | 3-1/2 | 4 | 4-1/2 | 5 | 5-1/2 | 6 | 7 | 8 | 9 | 10 | 11 | 12 |
| 3 | 3.500 | 2-5/8 | | | | 3 | 3-1/2 | 4 | 4-1/2 | 5 | 5-1/2 | 6 | 7 | 8 | 9 | 10 | 11 | 12 |
| 4 | 4.500 | 2-7/8 | | | | | | 4 | 4-1/2 | 5 | 5-1/2 | 6 | 7 | 8 | 9 | 10 | 11 | 12 |
| 5 | 5.563 | 3 | | | | | | | 4-1/2 | 5 | 5-1/2 | 6 | 7 | 8 | 9 | 10 | 11 | 12 |
| 6 | 6.625 | 3-1/8 | | | | | | | 4-1/2 | 5 | 5-1/2 | 6 | 7 | 8 | 9 | 10 | 11 | 12 |

| PROJECT | APPROVAL STAMP |
|-----------------|--|
| PROJECT: | <input type="checkbox"/> APPROVED |
| ADDRESS: | <input type="checkbox"/> APPROVED AS NOTED |
| ENGINEER: | <input type="checkbox"/> NOT APPROVED |
| SUBMITTAL DATA: | REMARKS: |
| NOTES 1: | |
| NOTES 2: | |