

POST INDICATOR VALVE WITH FLANGE ENDS

MODEL - LVPIVFF, LVPIVMJMJ



DESCRIPTION:

- Valves comply with AWWA C515-15 Standard
- Non-Rising Stem, resilient seated (EDPM encapsulated wedge)
- Triple O-Ring Seal
- Available with optional test plug on valve body (special order)
- Post Indicator Valves provided with universal "Indicator Post Plate"
- Mechanical Joint Ends to AWWA C153/A21.53
- Flanged Ends to ANSI B16.1, CLASS 125
- UL/Listed/FM Approved at 300 PSI water working pressure rating
- NSF/ANSI/CAN 61 certified as lead-free for use in drinking water systems
- Temperature range: 42°-180° F
- Fusion bonded epoxy coated interior and exterior to AWWA C550 standard
- Flanged Valves available with hand wheel or operating nut

*Flanged ends shown, LVPIVFF.
Available with Mechanical Joint
(MJ) ends. Model # LVPIVMJMJ

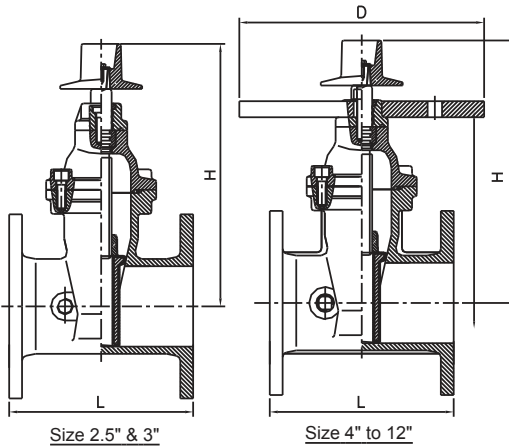

MATERIAL SPECIFICATIONS		
PART	MATERIAL	ASTM SPEC.
Body	Ductile Iron	A536 65-45-12
Wedge	Ductile Iron	EPDM Encapsulated
Wedge Nut	Bronze	B62 C83600
Stem	Stainless Steel	ISI 304
Bonnet	Ductile Iron	A536 65-45-12
Gasket	Rubber	EPDM
Gland	Ductile Iron	A536 65-45-12
Thrust Collar	Bronze	B62 C83600
O-Ring	Rubber	EPDM
Post Flange	Ductile Iron	A536 65-45-12
Operating Nut	Ductile Iron	A536 65-45-12
NPT Plug	Bronze	Commercial
Post Flange	Bolt	Stainless Steel AISI 316
Bonnet Bolt	Stainless Steel	AISI 304

VALVE DIMENSIONS							
Size (in.)	3	4	5	6	8	10	12
L (in.)	8	9	10	10-1/2	11-1/2	13	14
H (in.)	11-5/8	13-3/4	16-1/8	17-5/16	21-7/16	25-5/8	28-3/4
D (in.)		12	12	12	12	12	12
Weight (lbs.)	41	64	79	103	161	235	339

PROJECT	APPROVAL STAMP
PROJECT:	<input type="checkbox"/> APPROVED
ADDRESS:	<input type="checkbox"/> APPROVED AS NOTED
ENGINEER:	<input type="checkbox"/> NOT APPROVED
SUBMITTAL DATA:	REMARKS:
NOTES 1:	
NOTES 2:	