

# PIPE NIPPLES

## MODEL LVWGSPN



EX28936



### DESCRIPTION:

- **DIMENSIONS:** ASTM A733 (See table below for standard sizes)
- **THREADS:** NPT per ASME B1.20.1
- **MATERIAL:** ASTM A53, Sch 40 welded steel Pipe
- **FINISH:** Hot Dipped Galvanized (as Indicated)
- Specials Available upon request - TxG, GxG, GxPE, BxB\*
- Globally sourced
- Meets NSF61\*

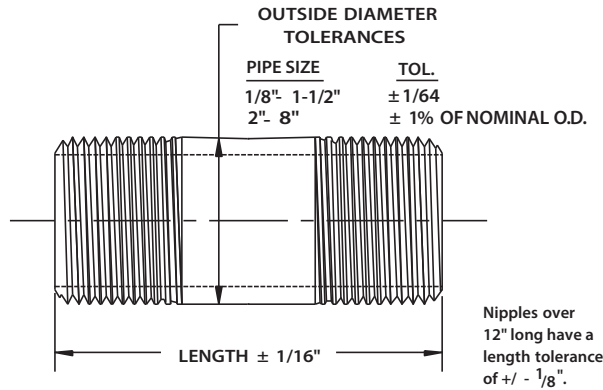

**Note:** Ready cut Black Nipples available 1/4" to 4" up to 72" long  
Galv. - 1/4" to 4" and 6" to 72" long

\*Galvanized only

PIPE SIZE (in.)	PIPE O.D.	C L (in.)	PIPE LENGTH (in.)															
			1-1/2	2	2-1/2	3	3-1/2	4	4-1/2	5	5-1/2	6	7	8	9	10	11	12
1/8*	0.405	3/4	1-1/2	2	2-1/2	3	3-1/2	4	4-1/2	5	5-1/2	6	7	8	9	10	11	12
1/4*	0.540	7/8	1-1/2	2	2-1/2	3	3-1/2	4	4-1/2	5	5-1/2	6	7	8	9	10	11	12
3/8*	0.675	1	1-1/2	2	2-1/2	3	3-1/2	4	4-1/2	5	5-1/2	6	7	8	9	10	11	12
1/2*	0.840	1-1/8	1-1/2	2	2-1/2	3	3-1/2	4	4-1/2	5	5-1/2	6	7	8	9	10	11	12
3/4*	1.050	1-3/8	1-1/2	2	2-1/2	3	3-1/2	4	4-1/2	5	5-1/2	6	7	8	9	10	11	12
1*	1.315	1-1/2		2	2-1/2	3	3-1/2	4	4-1/2	5	5-1/2	6	7	8	9	10	11	12
1-1/4*	1.660	1-5/8		2	2-1/2	3	3-1/2	4	4-1/2	5	5-1/2	6	7	8	9	10	11	12
1-1/2*	1.900	1-3/4		2	2-1/2	3	3-1/2	4	4-1/2	5	5-1/2	6	7	8	9	10	11	12
2*	2.375	2			2-1/2	3	3-1/2	4	4-1/2	5	5-1/2	6	7	8	9	10	11	12
2-1/2*	2.875	2-1/2				3	3-1/2	4	4-1/2	5	5-1/2	6	7	8	9	10	11	12
3*	3.500	2-5/8				3	3-1/2	4	4-1/2	5	5-1/2	6	7	8	9	10	11	12
3-1/2*	4.000	2-3/4					3-1/2	4	4-1/2	5	5-1/2	6	7	8	9	10	11	12
4*	4.500	2-7/8						4	4-1/2	5	5-1/2	6	7	8	9	10	11	12
5	5.563	3							4-1/2	5	5-1/2	6	7	8	9	10	11	12
6	6.625	3-1/8							4-1/2	5	5-1/2	6	7	8	9	10	11	12

\* AVAILABLE HDG

PROJECT	APPROVAL STAMP
PROJECT:	<input type="checkbox"/> APPROVED
ADDRESS:	<input type="checkbox"/> APPROVED AS NOTED
ENGINEER:	<input type="checkbox"/> NOT APPROVED
SUBMITTAL DATA:	REMARKS:
NOTES 1:	
NOTES 2:	