

PIPE NIPPLES

MODEL LVWGSPN



FEATURES:

- **DIMENSIONS:** ASTM A733 (See table below for standard sizes)
- **THREADS:** NPT per ASME B1.20.1
- **MATERIAL:** ASTM A53, Sch 40 Welded Steel Pipe
- **FINISH:** Black, or Hot Dip Galvanized (as indicated)
- Specials Available upon request - TxG, GxG, GxPE, BxB
- Globally sourced

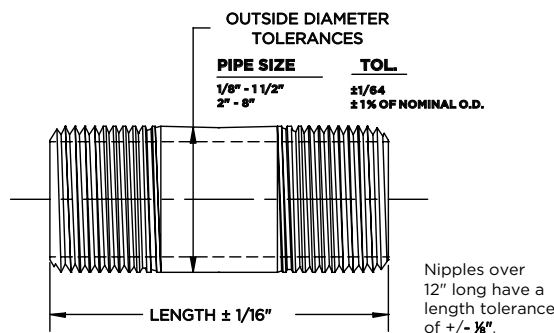

Note: Ready cut Black Nipples available 1/4" to 4" up to 72" long
Galv. - 1/4" to 4" and 6" to 72" long

| PIPE SIZE (IN) | PIPE O.D. | C L | PIPE LENGTH | | | | | | | | | | | | | | | | |
|----------------|-----------|-------|-------------|---|-------|---|-------|---|-------|---|-------|---|---|---|---|----|----|----|--|
| | | | 1 1/2 | 2 | 2 1/2 | 3 | 3 1/2 | 4 | 4 1/2 | 5 | 5 1/2 | 6 | 7 | 8 | 9 | 10 | 11 | 12 | |
| 1/8 * | 0.405 | 3/4 | | | | | | | | | | | | | | | | | |
| 1/4 * | 0.540 | 7/8 | | | | | | | | | | | | | | | | | |
| 3/8 * | 0.675 | 1 | | | | | | | | | | | | | | | | | |
| 1/2 * | 0.840 | 1 1/8 | | | | | | | | | | | | | | | | | |
| 3/4 * | 1.050 | 1 1/4 | | | | | | | | | | | | | | | | | |
| 1 * | 1.315 | 1 1/2 | | | | | | | | | | | | | | | | | |
| 1 1/4 * | 1.660 | 1 3/4 | | | | | | | | | | | | | | | | | |
| 1 1/2 * | 1.900 | 2 | | | | | | | | | | | | | | | | | |
| 2 * | 2.375 | 2 1/4 | | | | | | | | | | | | | | | | | |
| 2 1/2 * | 2.875 | 2 3/4 | | | | | | | | | | | | | | | | | |
| 3 * | 3.500 | 3 | | | | | | | | | | | | | | | | | |
| 3 1/2 * | 4.000 | 3 1/4 | | | | | | | | | | | | | | | | | |
| 4 * | 4.500 | 3 1/2 | | | | | | | | | | | | | | | | | |
| 5 | 5.563 | 3 3/4 | | | | | | | | | | | | | | | | | |
| 6 | 6.625 | 4 | | | | | | | | | | | | | | | | | |

* AVAILABLE HDG

| PROJECT | APPROVAL STAMP |
|-----------------|--|
| PROJECT: | <input type="checkbox"/> APPROVED |
| ADDRESS: | <input type="checkbox"/> APPROVED AS NOTED |
| ENGINEER: | <input type="checkbox"/> NOT APPROVED |
| SUBMITTAL DATA: | REMARKS: |
| NOTES 1: | |
| NOTES 2: | |