

OS&Y RESILIENT SEATED GATE VALVE with FLANGED ENDS

MODEL LV-OSYFF-363



DESCRIPTION:

The Lansdale NRS Resilient Seated Gate Valve with Flanged Ends, Model LV-OSYFF-363 is used as a control valve for on/off applications.

- Valves comply with AWWA C515-15 standard
- OS&Y Resilient seated (EDPM encapsulated wedge)
- Triple O-Ring seal
- Available open right, please specify
- Flanged ends to ANSI B161, Class 125/150
- UL Listed/FM Approved at 363 PSI water working pressure rating
- NSF/ANSI/CAN 61 certified as lead-free for use in drinking water systems
- Fusion bonded epoxy coated interior and exterior to AWWA C550 standard

*Available with MJ and grooved connections including: MJxMJ; GxG; FLxMJ; GxFL

INSTALLATION:

Refer to Lansdales' O&M manual for further information and installation instructions.

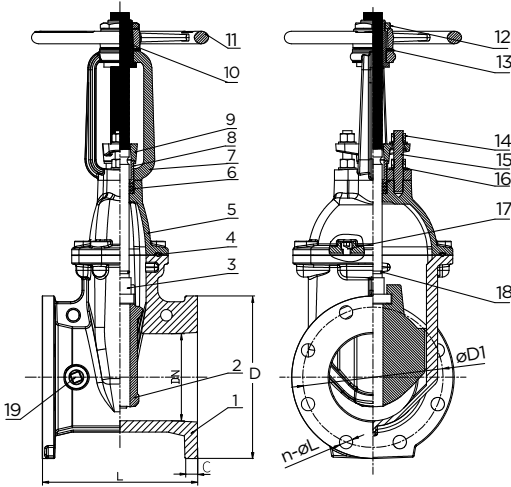

DIMENSIONS (in.)					
SIZE (in.)	L	D	D1	C	n-ØL
2	7.00	6.00	4.75	.63	4-3/4"
2-1/2	7.48	7.00	5.50	.70	4-3/4"
3	8.00	7.50	6.00	.75	4-3/4"
4	9.00	9.00	7.50	.75	8-3/4"
5	10.00	10.00	8.50	.75	8-7/8"
6	10.50	11.00	9.50	.75	8-7/8"
8	11.50	13.50	11.75	.87	8-7/8"
10	13.00	16.00	14.25	.94	12-1"
12	14.00	19.00	17.00	1.00	12-1"

MATERIAL SPECIFICATIONS			
PART NO.	PART NAME	MATERIAL	ASTM SPEC.
1	Valve Body	Ductile Iron	A536 65-45-12
2	Resilient Wedge Disc	Ductile Iron	A536 65-45-12 + EPDM
3	Stem	Stainless Steel	TY304
4	Bonnet Gasket	EPDM	—
5	Bonnet	Ductile Iron	A536 65-45-12
6	Stem Packing	EPDM	—
7	Yoke	Ductile Iron	A536 65-45-12
8	Stem Bushing	Brass	B62/C83600
9	Gland Flange	Ductile Iron	A536 65-45-12
10	Wedge Nut	Brass	B62/C83600
11	Hand Wheel	Ductile Iron	A536 65-45-12
12	Nut	Stainless Steel	TY304
13	Washer	Brass	B62/C83600
14	Gland Nut	Stainless Steel	TY304
15	Stud	Stainless Steel	TY304
16	Flat Washer	Stainless Steel	TY304
17	Bolt	Stainless Steel	TY304
18	O-Ring	NBR	—
19	Plug	Brass	B62/C83600

PROJECT	APPROVAL STAMP
PROJECT:	<input type="checkbox"/> APPROVED
ADDRESS:	<input type="checkbox"/> APPROVED AS NOTED
ENGINEER:	<input type="checkbox"/> NOT APPROVED
SUBMITTAL DATA:	REMARKS:
NOTES 1:	
NOTES 2:	