

# OS&Y RESILIENT SEATED GATE VALVE FLANGED X GROOVED ENDS, 3"- 8"

MODEL LVOSYFG



## GENERAL SPECIFICATIONS:

- Complies with AWWA C515
- Heavy Duty handwheel and attachment nut
- Triple O-rings stem seal
- NPT brass plug on body
- Groove to AWWA C606 standard
- Working pressure 300 psi
- Internally and externally fusion bonded epoxy powder coated (FBE)

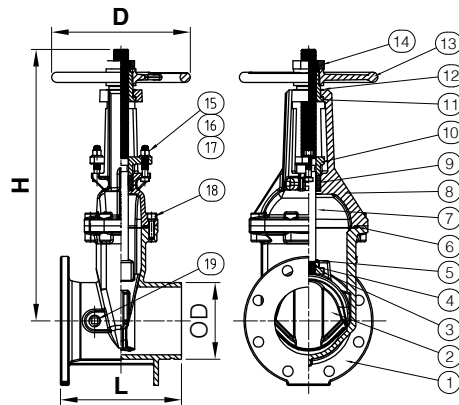

VALVE DIMENSIONS				
Size	3	4	6	8
	in	in	in	in
OD	3 1/2	4 1/2	6 5/8	8 5/8
L	8	9	10 1/2	11 1/2
H (open)	18 7/8	21 5/8	29 1/8	36 5/8
H (close)	15 3/4	17 3/4	23 1/4	28 3/4
D	10	10	12	14

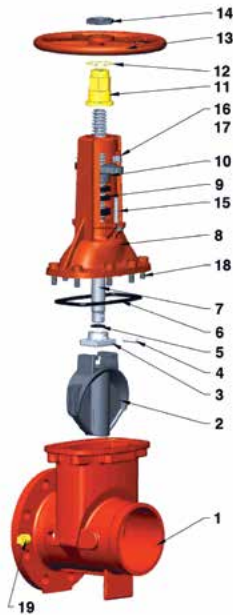

MATERIAL SPECIFICATIONS			
No.	PART	MATERIAL	ASTM SPEC.
1	Body	Ductile Iron	536 65-45-12
2	Wedge	Ductile Iron EPDM Encapsulated	
3	Wedge Nut	Stainless Steel	AISI 304
4	Pin	Stainless Steel	AISI 420
5	O-Ring	EPDM	
6	Gasket	EPDM	
7	Stem	Stainless Steel	AISI 304
8	Bonnet	Ductile Iron	A536 65-45-12
9	Packing	Graphite	
10	Gland	Ductile Iron	A536 65-45-12
11	Yoke Nut	Bronze	C95200
12	Washer	Brass	
13	Handwheel	Ductile Iron	A536 65-45-12
14	Handwheel Nut	Ductile Iron	A536 65-45-12
15	Bolts	Stainless Steel	A2-70
16	Nuts	Stainless Steel	A4-70
17	Washers	Stainless Steel	AISI 304
18	Bonnet Bolt	Carbon Steel	Gr8.8, Zinc Plated
19	Plug	Malleable Iron	

PROJECT	APPROVAL STAMP
PROJECT:	<input type="checkbox"/> APPROVED
ADDRESS:	<input type="checkbox"/> APPROVED AS NOTED
ENGINEER:	<input type="checkbox"/> NOT APPROVED
SUBMITTAL DATA:	REMARKS:
NOTES 1:	
NOTES 2:	