

NRS RESILIENT SEATED GATE VALVE MECHANICAL JOINT X MECHANICAL JOINT

MODEL LVNRSMJ

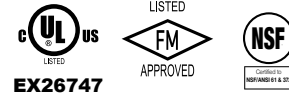

GENERAL SPECIFICATIONS:

- Valves comply with AWWA C515-15 Standard
- Non-Rising Stem, Resilient Seated (EDPM encapsulated wedge)
- Triple O-Ring Seal
- Available with Optional Test Plug on valve body (special order)
- Post Indicator Valves provided with universal "Indicator Post Plate"
- Mechanical Joint Ends to AWWA C153 /A21.53 Standard
- Flanged Ends to ANSI B16.1, Class 125
- UL Listed/FM Approved at 300 psi water working pressure rating
- NSF-61 and NSF-372 Certified as Lead-Free for use in drinking water systems
- Temperature Range: 42° - 180° F.
- Fusion Bonded Epoxy Coated Interior and Exterior to AWWA C550 Standard
- Flanged Valves available with Hand Wheel or Operating Nut

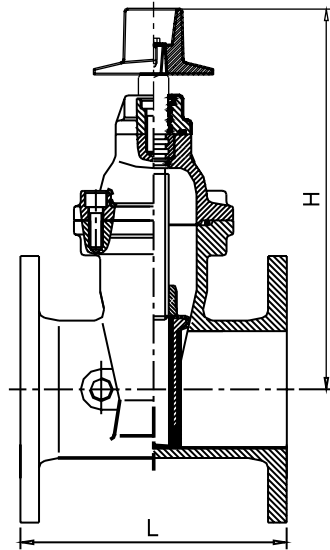

Part Name	Material	ASTM. Spec.
Body	Ductile Iron	A536 65-45-12
Wedge	Ductile Iron	EPDM Encapsulated
Wedge Nut	Bronze	B62 C83600
Stem	Stainless Steel	AISI 304
Bonnet	Ductile Iron	A536 65-45-12
Gasket	Rubber	EPDM
Gland	Ductile Iron	A536 65-45-12
Thrust Collar	Bronze	B62 C83600
O-Ring	Rubber	EPDM
Post Flange	Ductile Iron	A536 65-45-12
Operating Nut	Ductile Iron	A536 65-45-12
NPT Plug	Bronze	Commercial
Post Flange	Bolt	Stainless Steel AISI 316
Bonnet Bolt	Stainless Steel	AISI 304

DIMENSIONS (In)						
Size	3"	4"	6"	8"	10"	12"
L	9 1/2	10	11 1/2	12 1/2	14 3/4	14 7/8
H	11 5/8	13 3/4	17 15/16	21 7/16	25 3/8	28 3/4
D		12	12	12	12	12
WT. (lbs.)	45	71	116	176	280	386

PROJECT	APPROVAL STAMP
PROJECT:	<input type="checkbox"/> APPROVED
ADDRESS:	<input type="checkbox"/> APPROVED AS NOTED
ENGINEER:	<input type="checkbox"/> NOT APPROVED
SUBMITTAL DATA:	REMARKS:
NOTES 1:	
NOTES 2:	