

Automatic Air Valve

FIG. LV9208

Specifications

- The LV9208 is a high performance automatic air valve. The resilient seat offers a 100% reliable seal. The single chamber design offers better performance than double chamber designs. The intake and exhaust speed can reach the speed of sound. The design is ruggedly simple of corrosion resistant stainless steel
- EPDM sealing ring
- Flanged and drilling complies with EN1092-2 PN16(Other types are available on request)
- Outlet female thread acc. to DIN ISO 228

Working Pressure and Temperature

- 0.2 bar to 16 bar rated at -10°C to 120°C

Corrosion Protection

- Fusion bonded coating or liquid epoxy painted interior and exterior

Material Specifications

Part	Material	EN Specification	ASTM Specification
Body	Ductile Iron	EN1563, EN-GJS-450-10	A536 65-45-12
Float Ball Protector	Stainless Steel	EN10088-3, X5CrNiMo17-12-2	A276 Grade 316
Float Ball	Stainless Steel	EN10213, GX5CrNiMo19-11-2	A351 Grade CF8M
Rubber Washer	Rubber	EN681, EPDM	D2000 EPDM
Disc	Stainless Steel	EN10088-3, X5CrNiMo17-12-2	A276 Grade 316
Spacer	Stainless Steel	EN10088-3, X5CrNiMo17-12-2	A276 Grade 316
Gasket	Rubber	EN681, EPDM	D2000 EPDM
Bonnet	Ductile Iron	EN1563, EN-GJS-450-10	A536 65-45-12
Guide Sleeve	Stainless Steel	EN10088-3, X5CrNiMo17-12-2	A276 Grade 316

Schematic

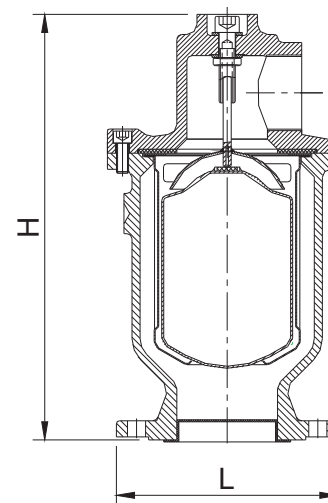

Main Dimensions (mm)

Size	DN50	DN80	DN100	DN150	DN200
L	165	200	220	285	340
H	349	349	423	552	552

Notes

- Designs, materials and specifications shown are subject to change without notice due to the continuous development of our products.