

## Globe Valve

FIG. LV6125

### Specifications

- Valves comply with DIN3356
- Metal seat
- Adjustable stem seal
- Packing replaceable under pressure
- Available with flanges EN1092-2 PN10 or PN16, ANSI B16.1 Class 125 (other types available on request )
- Face-to-face length in accordance with DIN3202 series F1

### Working Pressure and Temperature

- 16 bar rated at -10°C to 120°C

### Corrosion Protection

- Internally and externally liquid epoxy painted

### Material Specifications

Part Name	Material	EN Specification
Body	Grey Cast Iron	EN1561 EN-GJL-250
Bonnet	Grey Cast Iron	EN1561 EN-GJL-250
Body Trim	Stainless Steel	EN 10088 X5CrNi18-10
Disc Trim	Stainless Steel	EN 10088 X5CrNi18-10
Disc	Grey Cast Iron	EN1561 EN-GJL-250
Stem	Stainless Steel	EN10088, X20Cr13
Packing	Graphite	Non-asbestos
Gasket	Graphite	Non-asbestos
Yoke Bushing	Brass	2874 CZ 124
Handwheel	Grey Cast Iron	EN1561 EN-GJL-250

### Schematic

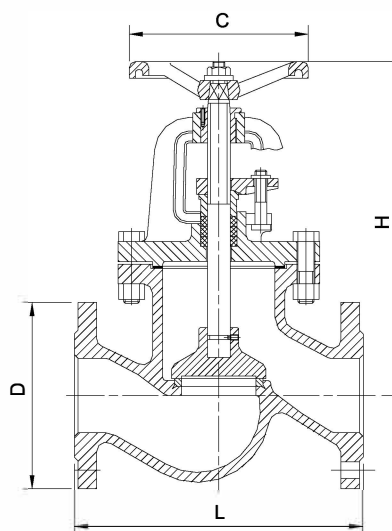
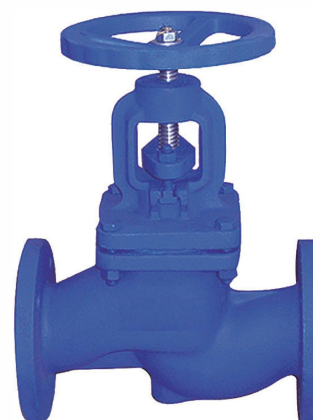

### Dimensions (mm)

Size	DN15	DN20	DN25	DN32	DN40	DN50	DN65
L	130	150	160	180	200	230	290
D	95	105	115	140	150	165	185
H	170	181	199	213	240	254	298
C	100	100	120	120	140	140	200

Size	DN80	DN100	DN125	DN150	DN200	DN250	DN300
L	310	350	400	480	600	730	850
D	200	220	250	285	340	405	460
H	345	375	384	438	546	648	760
C	200	240	280	320	356	515	515

#### Notes

- Designs, materials and specifications shown are subject to change without notice due to the continuous development of our products.