

AWWA C515 NRS Resilient Seated Gate Valve

FIG. LV3248

Specification

- Meet or exceed the requirements of AWWA C515 standard
- Full waterway
- 2" Square operating nut
- Rubber fully encapsulated Ductile Iron wedge
- Triple o-ring stem seal
- Face-to-face dimension complies with ASME B16.10
- Flange and drilling complies with ASTM B16.1 Class 125 (other flange types available upon request)

Working Pressure and Temperature

- 150 psi / 200 psi for size 2" to 30" rated at -10°C to 120°C
- 250 psi for size 2" to 18" rated at -10°C to 120°C

Corrosion Protection

- Fusion bonded coating interior and exterior meet or exceed all applicable of AWWA C550 standard

Options

- ASTM A276 Grade 316 stem
- Stainless steel fasteners: A2-70 or A4-70
- With post flange
- Operated with handwheel, operating nut, gearbox or actuator

Material Specifications

Part Name	Materials	ASTM Specification
Body	Ductile Iron	A536 65-45-12
Bonnet	Ductile Iron	A536 65-45-12
Wedge	EPDM Fully Encapsulated Ductile Iron Wedge	
Thrust Collar	Bronze	B148 C95200
Wedge Nut	Bronze	B148 C95200
Stem	Stainless Steel	A276 Grade 304
O-Ring	Rubber	D2000 BUNA-N
Gasket	Rubber	D2000 EPDM
Gland	Ductile Iron	A536 65-45-12
Fasteners	Carbon Steel	A307, Grade B
Operating Nut	Ductile Iron	A536 65-45-12
Handwheel	Ductile Iron	A536 65-45-12

Schematic

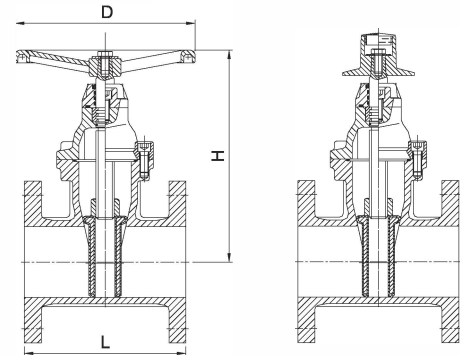

Size 2"-12"

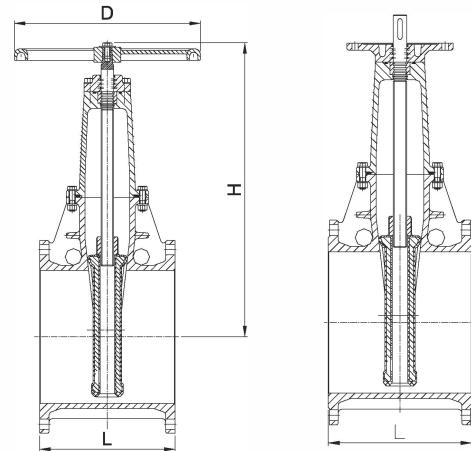

Size 14" and above

Dimensions (mm)

Size	2"	2-1/2"	3"	4"	5"	6"	8"	10"	12"	14"	16"	18"	20"	24"	30"
L	178	191	203	229	254	267	292	330	356	381	406	432	457	508	610
H	240	255	280	305	380	417	525	621	711	905	980	1115	1190	1340	1730
D	175	175	255	255	305	305	355	405	405	558	558	610	610	762	-

Notes

- Designs, materials and specifications shown are subject to change without notice due to the continuous development of our products.