

GROOVED SWING CHECK VALVE

MODEL LVCVGG



EXZ6984

FEATURES:



- Installed in both Horizontal or Vertical Line with upward Flow
- Easier and faster to maintain and install
- Low pressure drop
- EPDM non-stick leak tight sealing
- All stainless steel wetted parts to provide superior corrosion resistance
- Fusion bonded coating of interior and exterior meet or exceed all applicable AWWA C550 standard
- 350 PSI 2", 2-1/2", 3", 4", 6", 8"
- 300 PSI 5", 10", 12"
- UL/ULC Listed / FM Approved

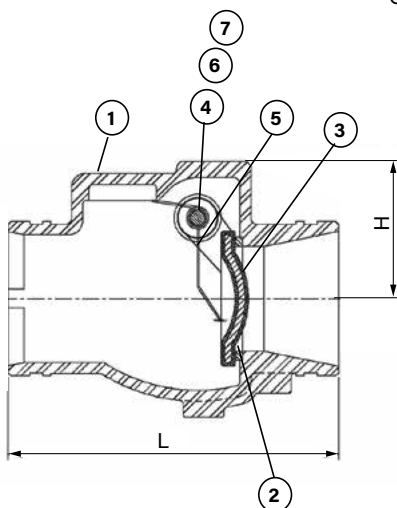

MATERIAL SPECIFICATION

PART NUMBER	PART	MATERIAL	ASTM SPECIFICATION
1	Body	Ductile Iron	A536 Grade 65-45-12
2	Body Seat Ring	Bronze	B62 C83600
3	Disc	Ductile Iron	A536 Grade 65-45-12
4	Hinge Pin	Stainless Steel	A276 Grade 304
5	Spring	Stainless Steel	A276 Grade 302
6	Hinge Pin Plug	Malleable Iron	A47 Grade 22010
7	Plug Sealing	Rubber	D2000 EPDM

DIMENSIONS

SIZE (IN)	1-1/4	1-1/2	2	2.5	3	4	5	6	8	10	12
L	6.3	6.3	6.7	7.2	7.8	8.6	10.5	10.6	12.8	17.0	19.5
H	2.5	2.5	2.5	3.0	3.5	4.0	4.5	5.5	6.5	8.0	8.5

PROJECT	APPROVAL STAMP
PROJECT:	<input type="checkbox"/> APPROVED
ADDRESS:	<input type="checkbox"/> APPROVED AS NOTED
ENGINEER:	<input type="checkbox"/> NOT APPROVED
SUBMITTAL DATA:	REMARKS:
NOTES 1:	
NOTES 2:	