

# AUXILIARY DRAIN DRUM DRIP

MODEL LVDD



**FEATURES:**

- Ready to Install
- Hot Dipped Galv.
- Rated to 175 psi
- Tested to 700 psi
- 36 Hour ice build up test with no damage

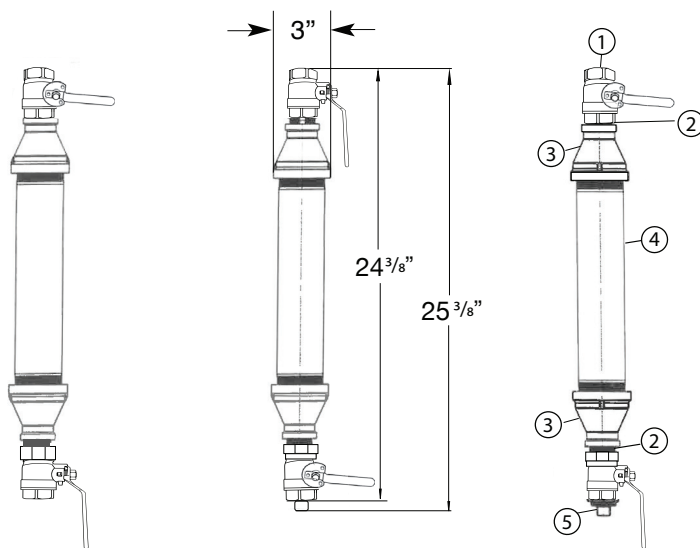

**DRAIN MODE**

**OPERATING MODE**

MATERIAL LIST	
NUMBER	DESCRIPTION
1	1" Lansdale Ball Valve
2	1" CL Nipple
3	2 x 1 Conc. Red
4	2 x 12 Sch 40 Pipe
5	1" Plug

PROJECT	APPROVAL STAMP
PROJECT:	<input type="checkbox"/> APPROVED
ADDRESS:	<input type="checkbox"/> APPROVED AS NOTED
ENGINEER:	<input type="checkbox"/> NOT APPROVED
SUBMITTAL DATA:	REMARKS:
NOTES 1:	
NOTES 2:	