

RING HANGER

MODELS LV-RH & LVRH



FEATURES:

- Material: Pre-galvanized steel
- Max temp: 450° F
- Knurled swivel nut provides vertical adjustment
- UL/FM Listed and Approved
- Complies with NFPA 13 requirements; ANSI/MSS SP-58-type 10
- Rounded edge design to avoid any abrasion to CPVC piping

1"

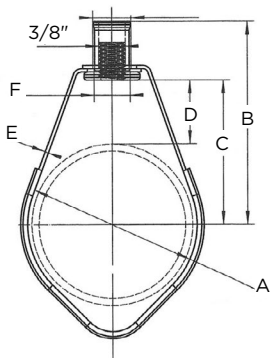

1-1/4" - 2"

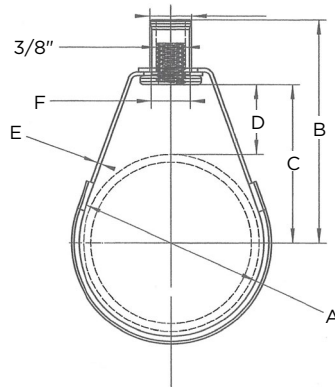

1/2" - 8"

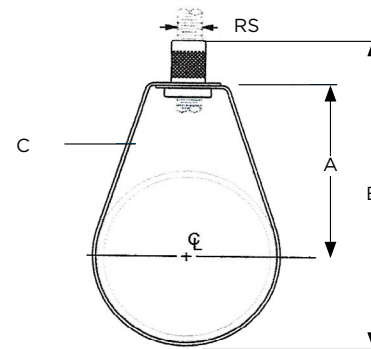

| CPVC RING HANGER | | | | | | | | | | |
|------------------|------------------|------------|----------------|---------|---------|---------|---------|------|---------|-------------|
| PIPE SIZE (In.) | MAX. LOAD (Lbs.) | WT. (Lbs.) | ROD SIZE (In.) | A (In.) | B (In.) | C (In.) | D (In.) | E | F (In.) | Width (In.) |
| 1 | 300 | .10 | 3/8 | 1.4 | 2.56 | 1.70 | 1.06 | 18GA | .53 | .63 |
| 1-1/4 | 300 | .10 | 3/8 | 1.75 | 2.62 | 1.75 | .93 | 18GA | .53 | .63 |
| 1-1/2 | 300 | .10 | 3/8 | 2.0 | 2.74 | 1.87 | .93 | 18GA | .53 | .63 |
| 2 | 300 | .11 | 3/8 | 2.48 | 3.0 | 2.13 | .93 | 18GA | .53 | .63 |

| ADJUSTABLE SWIVEL RING HANGER | | | | | | |
|-------------------------------|----------|------------|-------------|---------|---------|---------------|
| Pipe Size (In.) | Max Load | WT. (Lbs.) | Rod Size RS | A (In.) | B (In.) | C Width (In.) |
| 1/2 | 300 | 0.11 | 3/8 | 1-1/2 | 2-3/4 | 5/8 |
| 3/4 | | 0.11 | | 1-3/4 | 3-1/16 | |
| 1 | | 0.11 | | 1-7/8 | 3-5/16 | |
| 1-1/4 | | 0.11 | | 2 | 3-9/16 | |
| 1-1/2 | | 0.11 | | 2-3/16 | 3-7/8 | |
| 2 | | 0.12 | | 2-3/8 | 4-1/4 | |
| 2-1/2 | 525 | 0.22 | 3/8 | 3-1/16 | 5-3/16 | 13/16 |
| 3 | | 0.22 | | 3-1/4 | 5-11/16 | |
| 4 | 650 | 0.32 | 1/2 | 4 | 6-7/8 | |
| 5 | 1,000 | 0.57 | | 4-5/8 | 8-1/4 | |
| 6 | | 0.68 | 5-5/16 | 9-5/8 | | |
| 8 | | 1.05 | 7-1/4 | 12-3/8 | | |

| PROJECT | APPROVAL STAMP |
|-----------------|--|
| PROJECT: | <input type="checkbox"/> APPROVED |
| ADDRESS: | <input type="checkbox"/> APPROVED AS NOTED |
| ENGINEER: | <input type="checkbox"/> NOT APPROVED |
| SUBMITTAL DATA: | REMARKS: |
| NOTES 1: | |
| NOTES 2: | |