

BALL VALVE - FULL PORT

MODEL LVBV(UL/FM);
LVLFBV - LEAD FREE (UL)



FEATURES:

- Full-Port threaded ends (1/2" to 2" with CSA/UL/NSF61 Approval - No Lead)
- 2-Piece Forged Brass
- Female NPT Inlet and Outlet
- 600 WOG/CWP; 2 1/2" TO 4" - 400 WOG/CWP-600WOG/CWP Optional; 150 SWP
- Valves conform to Federal Specifications WW-V-35, Type II Class A, Style 3 and MSS SP-110



- UL Approval**
- Trim and Drain (300 psi)
 - Compressed Gas Shut-off Valves (600 psi)
 - Flammable Liquid Shut-off Valves (600 psi)
 - Gas Shut-off Valves (600 psi)
 - LP-Gas Shut-off Valves (600 psi)
 - Manual Valves (600 psi)



FM Approval
• 600 psi rating

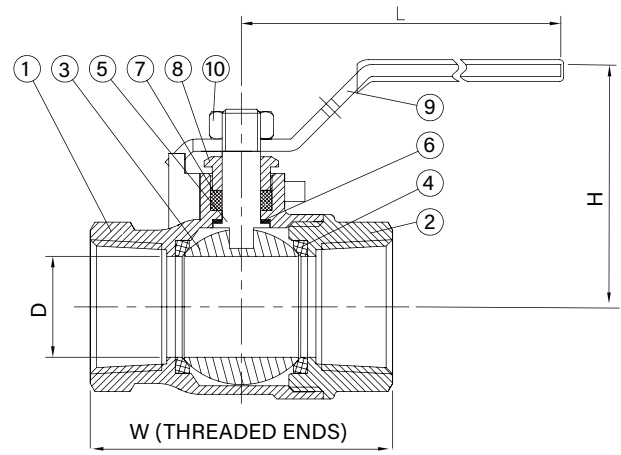

MATERIAL LIST		
NUMBER	DESCRIPTION	MATERIAL
1	Body	Forged Brass
2	End Cap	Forged Brass
3	Ball	Brass
4	Seat	PTFE
5	Stem	Brass (ASTM B16)
6	Thrust Washer	PTFE
7	Packing	PTFE
8	Gland	Brass
9	Handle	Carbon Steel Plated
10	Nut	Carbon Steel Plated

SIZE (In)	D	W	H	L
1/2	0.50	2.12	1.45	3.23
3/4	.75	2.41	1.78	3.94
1	0.98	2.96	2.29	4.72
1-1/4	1.22	3.28	2.44	4.72
1-1/2	1.50	3.67	3.00	7.09
2"	1.97	4.21	3.30	7.09
2-1/2	2.50	5.18	3.86	7.87
3	3.0	5.91	4.17	7.87

PROJECT	APPROVAL STAMP
PROJECT:	<input type="checkbox"/> APPROVED
ADDRESS:	<input type="checkbox"/> APPROVED AS NOTED
ENGINEER:	<input type="checkbox"/> NOT APPROVED
SUBMITTAL DATA:	REMARKS:
NOTES 1:	
NOTES 2:	