

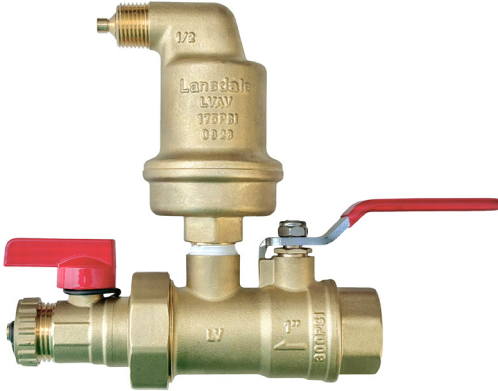

AUTOMATIC AIR VENT W/ ADJUSTABLE PURGE VALVE

MODEL LVAV-2



DESCRIPTION:

The Lansdale, "Automatic Air Vent w/Adjustable Purge Valve", Model LVAV-2 is a device consisting of a 1" ball valve, an air vent, strainer and adjustable purge valve. This device helps prevent corrosion from attacking the piping system by releasing trapped air in wet fire sprinkler piping systems. The integrated purge valve will quickly remove air from the system by attaching a hose to the valves connection and opening the valve while filling the system, this valve also offers a convenient way to clean the strainer. Once the system is operating the Automatic Vent will release any air introduced into the piping system, and act as a vacuum break when draining the system.

The LVAV-2 is UL Listed and meets NFPA 13 requirements that specifies that an air vent be placed into service on all wet sprinkler systems utilizing metal piping.

This device should be installed coming off the top of the piping in accordance with the designers location, and should have an isolation valve installed to allow service for this device.

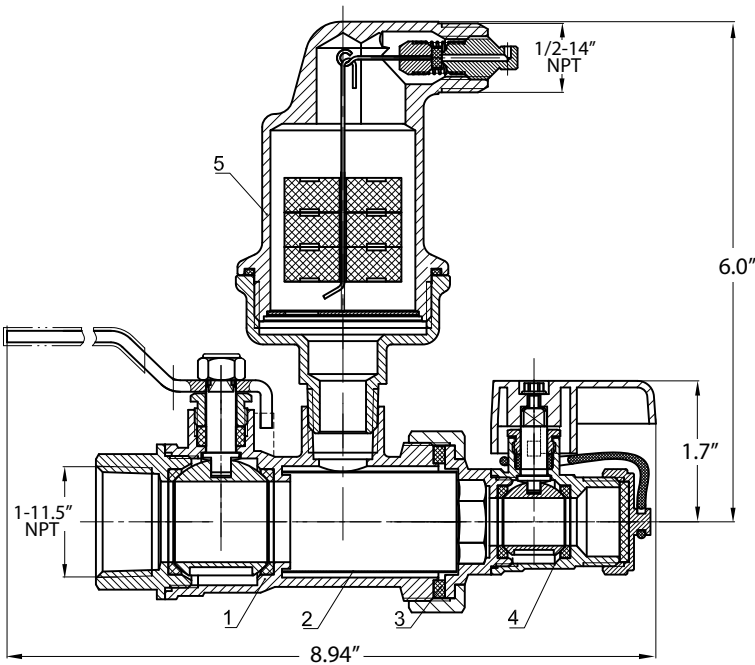

MATERIAL SPECIFICATIONS			
ITEM	DESCRIPTION		MATERIAL
1	Ball Valve	Sub-Assembly	Brass-C37700
2	Screen	C84400	—
3	Washer	PTFE	—
4	Purge Valve	Sub-Assembly	Brass-C37700
5	Automatic Air Release Valve	Sub-Assembly	Brass-C37700

PROJECT	APPROVAL STAMP
PROJECT:	<input type="checkbox"/> APPROVED
ADDRESS:	<input type="checkbox"/> APPROVED AS NOTED
ENGINEER:	<input type="checkbox"/> NOT APPROVED
SUBMITTAL DATA:	REMARKS:
NOTES 1:	
NOTES 2:	