

ANGLE TEST & DRAIN WITH ADJUSTABLE PRV & GAUGE

MODEL LVATD-RT



FEATURES:

- UL/FM - Listed and Approved
- Size Range: 3/4", 1", 1-1/4", 1-1/2", 2"
- Orifice Options: 2.8K, 4.2K, 5.6K, 8.0K, 11.2K, 25.2K
- 175 - 310 PSI Field Adjustable PRV
- 300PSI Stainless Steel Gauge
- 3-Way Globe Valve
- Tamper-Resistant Test Orifice and Sight Glass
- Horizontal or Vertical Installation
- NPT Connections conforms to ASME B1.20.01
- Manufactured in accordance to NFPA13, 13R, 13D

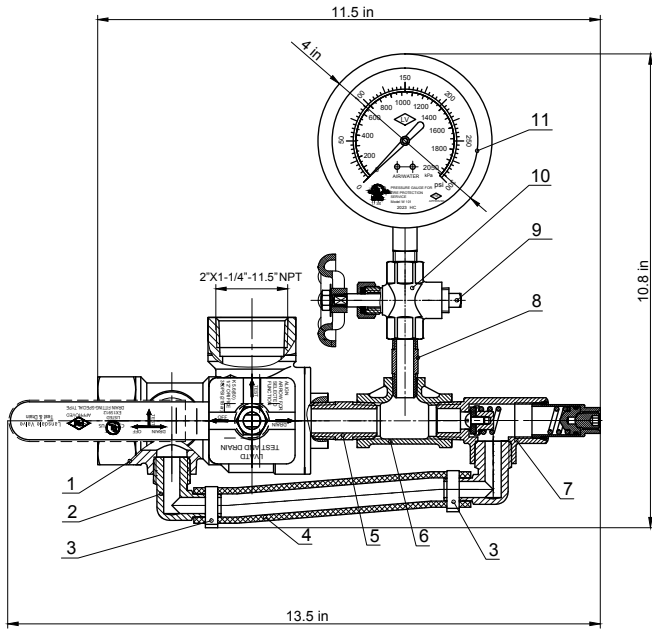

MATERIAL SPECIFICATIONS	
ITEM	DESCRIPTION
1	Test & Drain - MODEL LVATD
2	Hose Fittings
3	Hose Clamps
4	Hose
5	1/2" x 1-1/2" Black Nipple 1/2" x 1-1/2"
6	1/2" x 1/4" x 1/2" Malleable Iron Tee
7	1/2" 175 PSI - 310PSI Field Adjustable PRV
8	1/4" x 1-1/2" Black Nipple 1/4" x 1-1/2"
9	1/4" Malleable Iron Plug 1/4"
10	1/4" - 3 Way Valve
11	Air/Water Gauge- 300PSI

PROJECT	APPROVAL STAMP
PROJECT:	<input type="checkbox"/> APPROVED
ADDRESS:	<input type="checkbox"/> APPROVED AS NOTED
ENGINEER:	<input type="checkbox"/> NOT APPROVED
SUBMITTAL DATA:	REMARKS:
NOTES 1:	
NOTES 2:	