

ANGLE TEST & DRAIN WITH PRV

MODEL LVATD-R

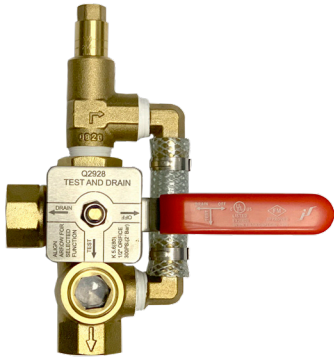

FEATURES:

- Multi function device allowing for system test (5.6K), system or floor drain, and "off" position.
- Field adjustable pressure relief valve 175 PSI - 310 PSI
- Integrated Sight Glass
- Angle design for ease of installation in difficult locations
- Rated for 300 psi
- Complies with all requirements of NFPA 13
- Designed to relieve excess pressure with built in PRV Valve
- UL/FM Listed and Approved

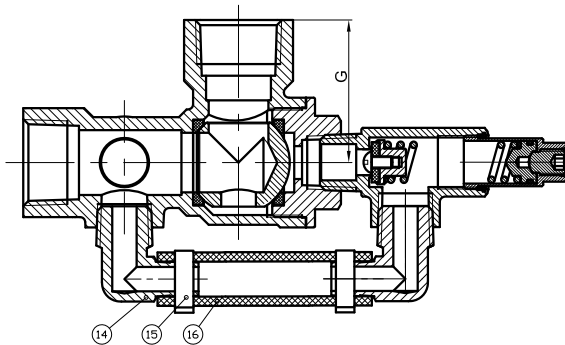
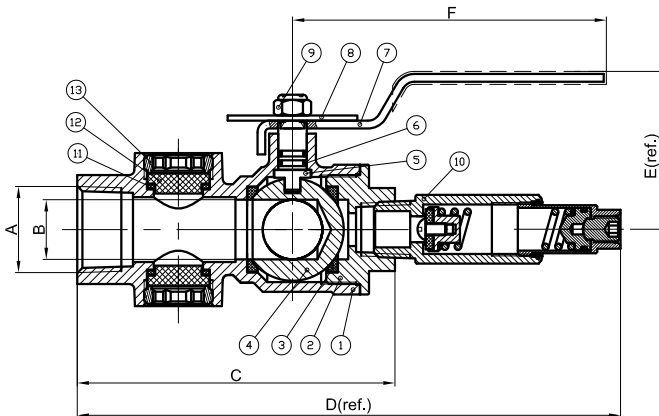

MATERIAL LIST		
NUMBER	DESCRIPTION	MATERIAL
1	Body	C37700
2	Cap	C37700
3	Seal	PTFE
4	Ball	C37700
5	Stem	C37700
6	O-Ring	NBR
7	Lever	Steel
8	Indicator Plate	Steel
9	Nut	Steel
10	Adjustable Relief Valve	Sub-Assembly
11	Washer	NBR
12	Sight Glass	Lexan
13	Retaining Ring	C37700

A (NPT)	B	C	D (ref)	E	F	G
¾"	0.67	4.21	7.64	2.2	4.76	1.81
1"	0.91	4.82	8.23	2.4	4.76	2.17
1¼"	1.18	5.26	8.66	2.83	5.55	2.36
1½"	1.5	5.28	9.09	3.22	6.34	2.56
2"	1.85	6.02	9.45	3.43	6.34	2.83

PROJECT	APPROVAL STAMP
PROJECT:	<input type="checkbox"/> APPROVED
ADDRESS:	<input type="checkbox"/> APPROVED AS NOTED
ENGINEER:	<input type="checkbox"/> NOT APPROVED
SUBMITTAL DATA:	REMARKS:
NOTES 1:	
NOTES 2:	