

ADJUSTABLE PRESSURE RELIEVE VALVE

MODEL LVAPR



FEATURES:

The Lansdale field adjustable relief valve is rated for up to 310 psi. The adjustable relief valve allows for the required NFPA field hydrostatic testing to be accomplished without removing and/or plugging the outlet for the relief valve. The Model LVAPR set pressure is field adjustable for system pressure of 175 psi to 310 psi. See Relief Valve Setting Procedure for detailed information.

Note: In accordance with NFPA 13, all wet pipe sprinkler systems must be equipped with a minimum 1/2" pressure relief valve.

- Maximum System Working Pressure: 310 psi
- Relief Valve Pressure Range: 175 psi to 310 psi

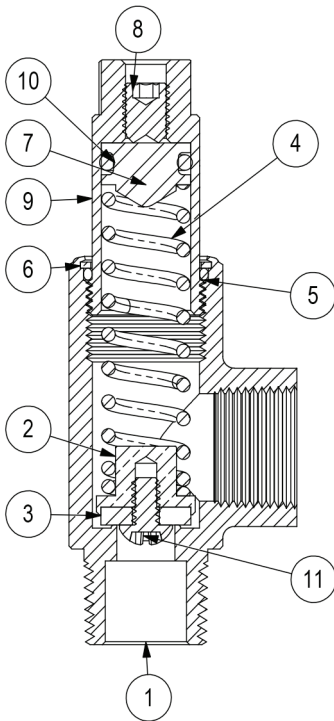

ADJUSTABLE RELIEF VALVE			
ITEM NO.	DESCRIPTION	MATERIAL	QTY.
1	Valve Body	Bronze	1
2	Valve Seat	Bronze	1
3	Sealing Rubber	EDPM	1
4	Spring Stainless	Steel	1
5	O-Ring	EDPM	1
6	Washer	Brass	1
7	Valve Piston	Stainless Steel	1
8	Pressure Adjustable Screw	Stainless Steel	1
9	Adjustment Cap	Bronze	1
10	Piston O-Ring	EDPM	1
11	Sealing Rubber Retaining Screw	Stainless Steel	1

ADJUSTABLE PRESSURE RELIEF VALVE

MODEL LVAPR

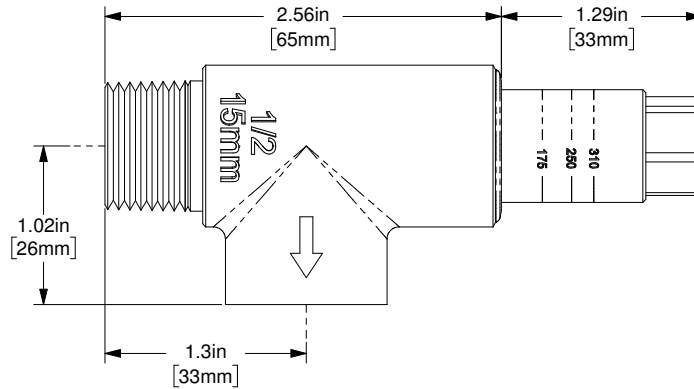

* **Note:** Valve showing in the fully open position. Model LVAPR is factory set a approximately 185 psi

MODEL LVAPR RELIEF VALVE SETTING PROCEDURE

The LVAPR Adjustable Pressure Relief Valve, is factory set to relieve at a pressure of approximately 185 psi. The Pressure Relief Valve may be adjusted to relieve at a higher pressure in accordance with the requirements of NFPA Standards for the authority having jurisdiction. The typical relief pressure point is nominal 10 psi above the expected normal system pressure. To reset the Model LVAPR pressure relief valve, rotate the hex cap clockwise for a higher pressure setting or counter clockwise for a lower pressure setting. Use the lines on the stem for an approximate relief pressure setting. One full turn of the hex cap will result in approximately 25 psi increase or decrease. To verify the new setting of the Model LVAPR Relief Valve, use a small hydrostatic pump attached to the supply. Increase the pressure at the relief valve to 10 psi above the expected normal system pressure. Readjust the LVAPR as needed to maintain approximately 10 psi higher relief setting.

PROJECT	APPROVAL STAMP
PROJECT:	<input type="checkbox"/> APPROVED
ADDRESS:	<input type="checkbox"/> APPROVED AS NOTED
ENGINEER:	<input type="checkbox"/> NOT APPROVED
SUBMITTAL DATA:	REMARKS:
NOTES 1:	
NOTES 2:	